

1 2 3 4 5 6 7 8

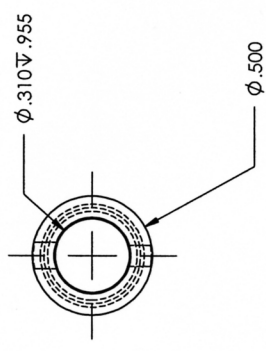
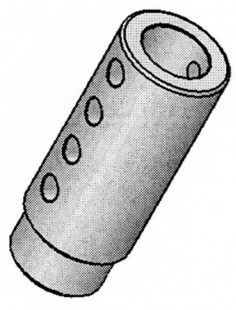
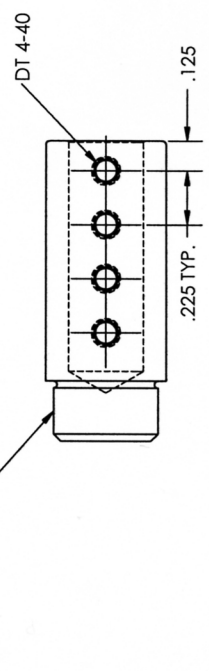
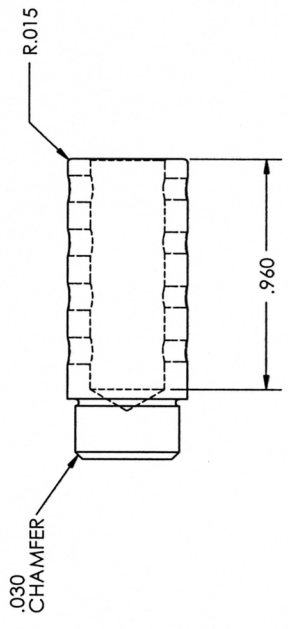
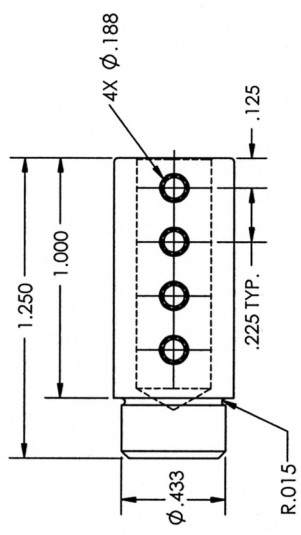

ALL UNDESIGNATED CHAMFERS: .005 X 45°

PROPRIETARY AND CONFIDENTIAL
 THE INFORMATION CONTAINED IN THIS DRAWING IS THE SOLE PROPERTY OF TTC @ CRUMP. IT IS TO BE USED FOR THE MANUFACTURE OF THE PART IDENTIFIED HEREIN ONLY. REPRODUCTION IN PART OR AS A WHOLE WITHOUT THE WRITTEN PERMISSION OF TTC @ CRUMP IS PROHIBITED.

UNLESS OTHERWISE SPECIFIED: DIMENSIONS ARE IN INCHES TOLERANCES FRACTIONAL ± ANGULAR: MACH ± BEND ± TWO PLACE DECIMAL ± THREE PLACE DECIMAL ±		DRAWN	NAME	DATE
		CHECKED		
		ENG APPR.		
		MFG APPR.		
		Q.A.		
INTERPRET GEOMETRIC TOLERANCING PER:		COMMENTS:		
MATERIAL		6061 Alloy		
FINISH				
NEXT ASSY	USED ON			
APPLICATION		DO NOT SCALE DRAWING		

TTC @ CRUMP
 TITLE:
SCOTTS TOGATOR
 SIZE DWG. NO. **B** REV
 SCALE: 2:1 WEIGHT: SHEET 1 OF 1

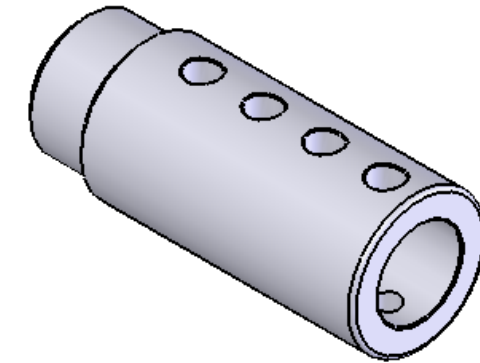
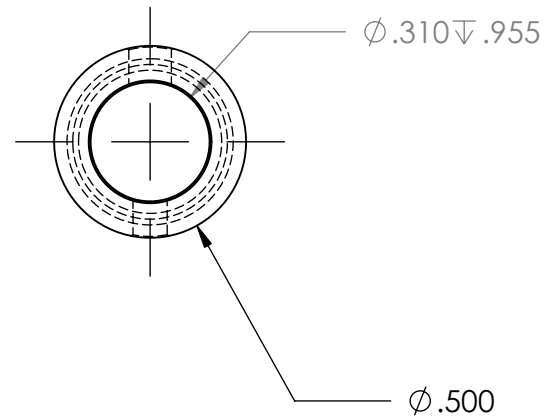
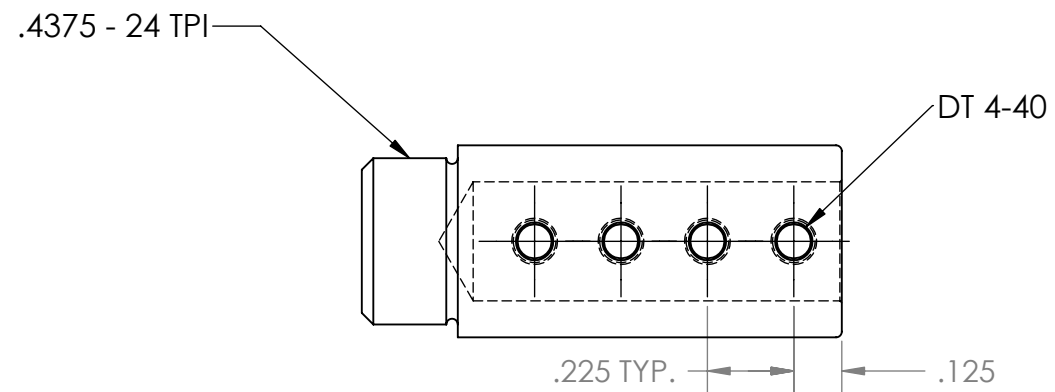
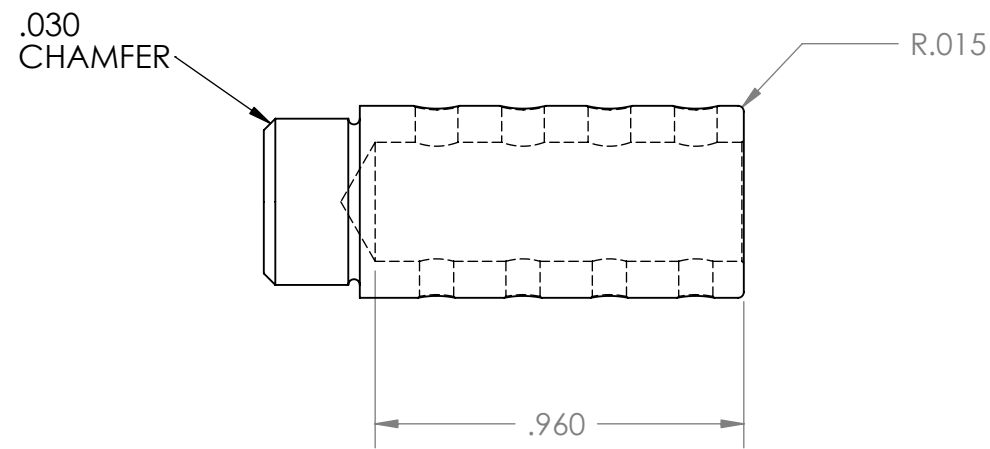
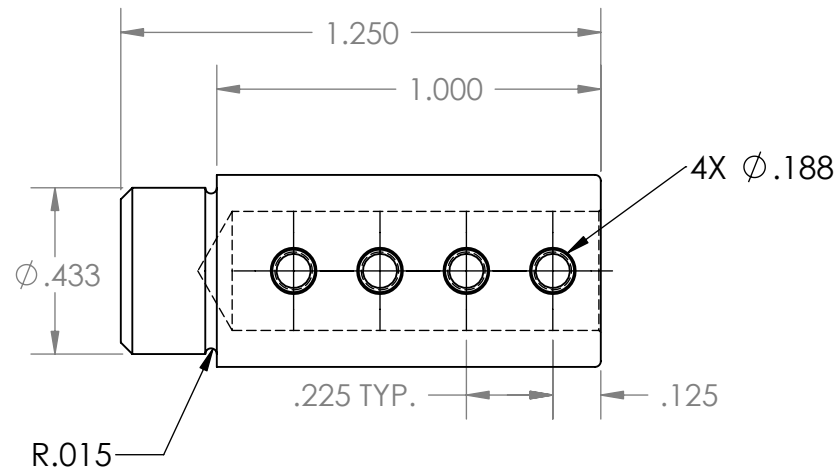

ALL UNDESIGNATED CHAMFERS: .005 X 45°

PROPRIETARY AND CONFIDENTIAL
 THE INFORMATION CONTAINED IN THIS DRAWING IS THE SOLE PROPERTY OF <INSERT COMPANY NAME HERE>. ANY REPRODUCTION IN PART OR AS A WHOLE WITHOUT THE WRITTEN PERMISSION OF <INSERT COMPANY NAME HERE> IS PROHIBITED.

		UNLESS OTHERWISE SPECIFIED:		NAME	DATE	TTC @ CRUMP		
		DIMENSIONS ARE IN INCHES TOLERANCES: FRACTIONAL ± ANGULAR: MACH ± BEND ± TWO PLACE DECIMAL ± THREE PLACE DECIMAL ±		DRAWN				TITLE: SCOTTS TOGATOR
		INTERPRET GEOMETRIC TOLERANCING PER:		CHECKED		SIZE	DWG. NO.	
		MATERIAL 6061 Alloy		ENG APPR.		B		
		FINISH		MFG APPR.			SCALE: 2:1	WEIGHT:
NEXT ASSY	USED ON	DO NOT SCALE DRAWING		Q.A.				
APPLICATION		COMMENTS:						